

INSTRUCTIONS

Part # 725-466
Fits; Ski-Doo F2000, S2000, & ZX chassis models.
(without electric start)

CHECKING OFFSET

1. Open the belt guard and remove the drive belt.
2. Install the alignment bar over the rear sheave of the drive clutch as shown in Figure # 2. When the alignment bar is in place the driven pulley should be in line with the tool as shown in Figure #2 at points 2 and 2A. If the offset is off at both points 2 and 2A adjustment will be needed.

CORRECTING OFFSET

1. To correct offset, the driven pulley must be moved laterally along the driven shaft. To do so you must first remove the driven pulley.
2. To move the driven pulley inwards on the shaft, remove washer(s) as required.
3. To move the driven pulley outwards on the shaft, add additional washer(s) behind the driven pulley.
4. Reinstall the driven pulley when the correct offset is aquired.

NOTE: Driven pulley should be tight up against the jackshaft shims and bearing while aligning.

CHECKING PARALLELISM

1. Check parallelism of the drive clutch/driven pulley using the alignment bar at points 2 and 2A as shown in Figure 2. If alignment is off at either point, adjustment will be needed. For motors frequently under heavy torque load, a 1.5mm (0.062in.) gap at point 2A is preferred by many tuners. This allows for some movement of the motor under heavy torque load and gives you the proper offset for optimum clutching.

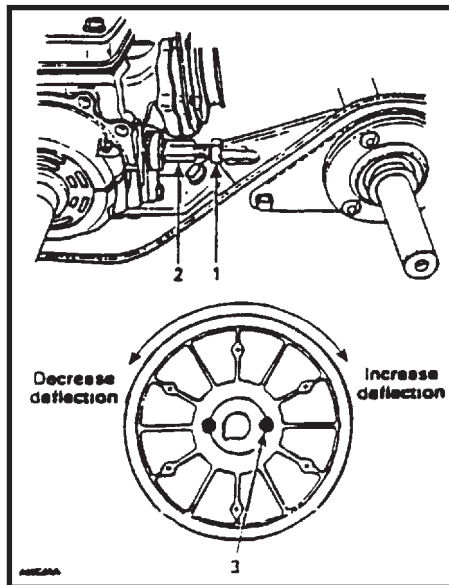

Figure 1
 Typical
 1. Jam Nut
 2. Adjuster
 3. Allen Screw with jam nut

CORRECTING PARALLELISM

1. To correct parallelism start by loosening the locking nut labeled 2 in Figure #1.
2. Back off torque rod labeled 1 in Figure #1.
3. Adjust the engine by loosening the motor mounts and points 1, 2, and 3 in contact with the alignment bar all at the same time.
4. Tighten motor mounts while checking alignment.
5. Adjust torque limiter rod and tighten locking nut.
6. Install drive belt and adjust belt deflection as needed.

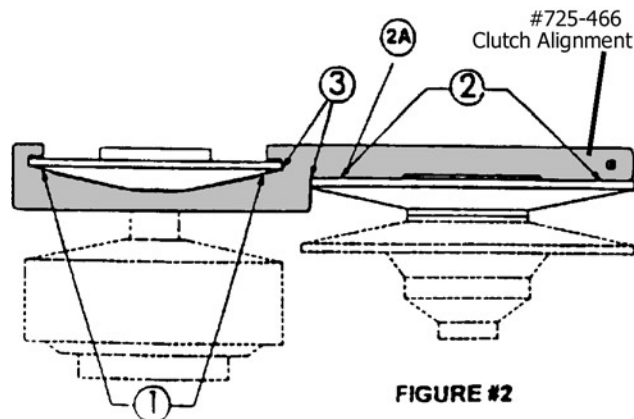

FIGURE #2