



Winter Package BASIC; Hand Warmers, Thumb Warmer and Controller

210039i_A

DO NO USE ON SNOWMOBILES OR OTHER DEVICES WITHOUT A REGULATED DC POWER SUPPLY. IT WILL NOT WORK!

Components: The Winter Package from Symtec, Inc. includes a set of Hand Warmers, an easy to apply Thumb Warmer, a dual function – 5 level Temperature Controller, the accessories to install these components, and Installation and Operating Instructions to assist vehicle owners.

Installation Instructions:

Mounting Hand and Thumb Warmers.

1. Remove grips (use compressed air if available). Clean handlebar to remove any residue and dry.
2. Non throttle side hand warmer: Peel release paper from back of hand warmer and position (non throttle side) heater with wire leads facing the driver. Remove air pockets by pressing with thumb and moving toward edge.
3. Throttle side hand warmer: Peel release paper from back of hand warmer and position heater with wire leads facing the driver.
4. Apply a high temperature, 2-part epoxy (such as Permatex Quick Set) to area where grips will be located.
5. Install grips (use compressed air if available) and let adhesive dry.
6. Peel the release paper from the Thumb Warmer and adhere it to the front side of the throttle.
7. Slide the piece of heat shrink tubing over the Thumb Warmer and throttle and use a heat gun or other heat source to shrink the tubing but be careful not to burn it.
8. Use one cable tie on the throttle to secure the wires and provide a strain relief.
9. Push the throttle full throttle, route wire using cable ties, leave relief in the wire so the throttle in the full open position does not strain the wire.

Mounting the Temperature Controller.

Determine if there is room to mount the Temperature Controller on the handlebar. If there is a good location follow the Option A instructions and Figure 1 for the handlebar mounting. If the controller would be more accessible mounted on a panel or other surface, follow Option B mounting instructions and refer to Figure 2.

Option A: Figure 1

1. If the handlebar is the smaller 7/8" diameter type insert the rubber spacer (item 8) and slide the handlebar mount (item 7) over the bar. For larger diameter bars, place the piece of electrical tape around the bar at the chosen mounting location. Slide the handlebar mount (item 7) over the taped bar. Insert a nut (item 4) into the side of the mount with the 6 sided recess. Install a screw (item 5) and tighten lightly.
2. Attach the Pivot (item 6) to the handlebar mount (item 7) with the shorter screw (item 2) and nut (item 4) inserted in the mount. Install a lock washer (item 3) between the two but do not tighten the screw securely.

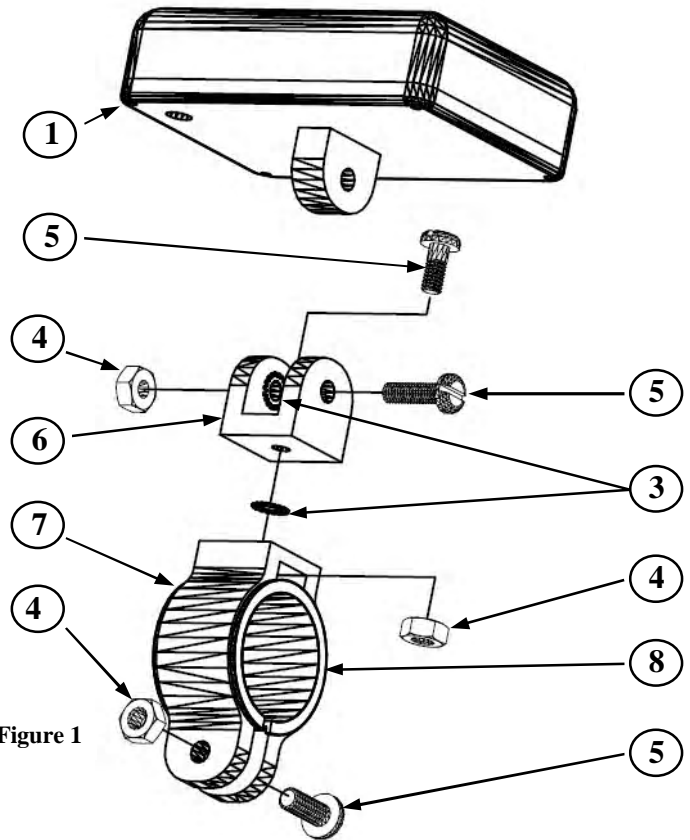

Figure 1

3. Place the tab on the bottom of the Temperature Controller (item 1) in the slot of the Pivot (item 6) and insert the screw (item 5). At this point rotate the handlebar mount (item 7), the Pivot, and the Temperature Controller to a location that provides the best view of the Controller to the driver.
4. Tighten the screw (item 5) on the bottom of the handlebar mount to secure it to the handlebar.
5. Without moving the Pivot, remove the screw holding the Controller to the Pivot (item 5) and set the Controller aside.
6. Securely tighten the screw (item 2) that attaches the Pivot to the handlebar mount fixing the Pivot angle.
7. Attach the Temperature Controller to the Pivot with the screw (item 5) and nut placed in the 6 sided recess of the Pivot. Insert a lock washer (item 3) in the slot of the Pivot along with the tab from the bottom of the Temperature Controller as the screw is inserted. The lock washer will keep the Controller from moving when the screw is tightened.
8. Rotate the Controller to the correct angle for viewing and tighten the screw.
9. Using the cable ties, route the wires from the Controller, Grips, and Thumb Warmer to a common connection point.

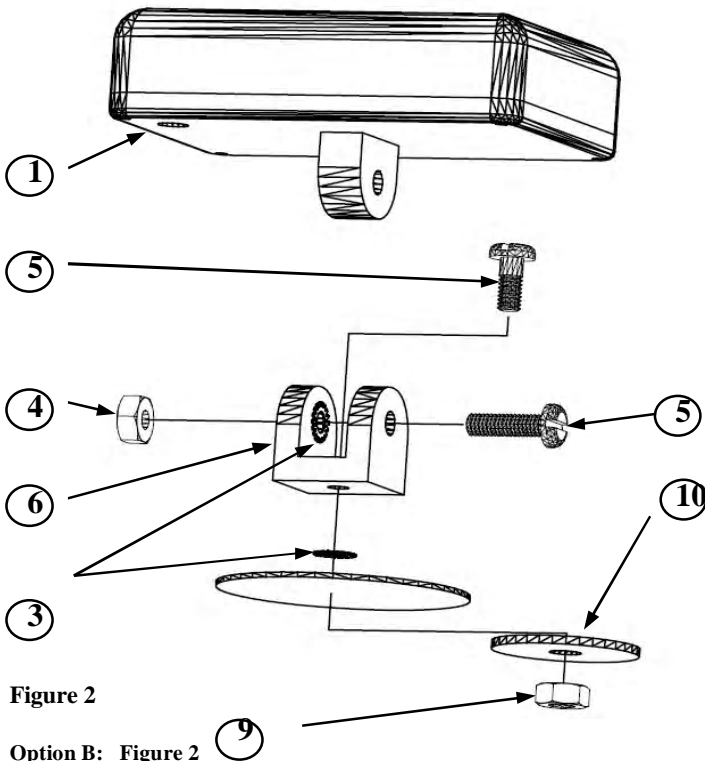

Figure 2

Option B: Figure 2

1. Attach the Temperature Controller (item 1) to the Pivot (item 6) with screw (item 5) and nut (item 4).
2. Choose a point on a panel or surface where the Controller will be mounted. The location should be chosen where a hole can be drilled in the panel and have access to install a washer and nut on the bottom side. Adjust the angle of the Controller for the best view for the driver and mark the angle that the Pivot will be installed.
3. Drill a 5/32" hole in the panel where the pivot should be mounted. **(Be sure that you do not drill into the gas tank)**
4. Separate the Controller and install the Pivot, at the angle marker previously, with the screw (item 5), removed from the bottom of the handlebar mount), fender washer (item 10), and locking nut (item 9). Place the locking washer (item 3) between the Pivot and the panel to keep it from rotating.
5. Attach the Controller (item 1) to the Pivot with the screw (item 5) and nut placed in the 6 sided recess of the Pivot. Insert a lock washer (item 3) in the slot of the Pivot along with the tab from the bottom of the Controller as the screw is inserted. The locking washer will keep the Controller from moving when the screw is tightened.

6. Rotate the Controller to the best angle for viewing and tighten the screw.
7. Using the cable ties, route the wires from the Controller, Grips, and Thumb Warmer to a common connection point.

Electrical Connections: Figure 3

Insert the pin connectors from the hand warmer to the center holes of the 6 pin connector. Assure they are secure and cannot come out.

1. Connect the 6 pin Female Connector from the hand and thumb warmer to the 6 pin male connector from the Temperature controller.
2. Connect the Red wire to 12V. Locate a voltage controlled power wire (such as one leading to a headlight taillight, or dash light). Using the red tap connector, place this power wire into the continuous channel and insert the red wire into (do not strip) into adjacent channel. Using pliers, press the metal contact flush with top of connector. Close the hinged cover until latched.
3. Connect the Black wire to a ground. For Ground connection use a frame component or a Ground wire, not a rubber isolated component such as a handlebar or a steering assembly. Use the red tap connector described in item 3 above or the ring terminal.

Operating Instructions: After the Winter package is installed on your vehicle you will be able to select and adjust the heat level of the Hand warmers and Thumb warmer. There are switches under the red circle marker "SELECT" and "POWER SET" on the Temperature Controller and these will be pressed to make the adjustments.

1. When the ignition is turned on the LED above the word "GRIPS" will be on.
2. With the "POWER SET" pad select the heat level for the Hand warmer Grips. Each time the pad is pressed another LED will light indicating a higher heat level. Pressing the pad 5 times will provide the highest level of heat. When the pad is pressed again the heat will be off and the heat level selection can start again.
3. Press the "SELECT" pad and the LED above the word "GRIPS" will go off and the LED above the word "THUMB" will light indicating the heat level of the Thumb warmer can be set.
4. Press the "POWER SET" pad to select the heat level for the Thumb warmer. Setting the heat level for the Thumb warmer will not affect the heat level set previously for the Hand warmers.
5. Pressing the "SELECT" pad will switch between the GRIP and THUMB allowing the heat level of each to be adjusted.
6. The Temperature Controller will shut off automatically after 2 hours if no adjustments are made. To reactivate the Temperature Controller press the "SELECT" pad and reset the desired heat levels.
7. Press both the "SELECT" and the "POWER SET" pads at the same time to change the light level of LED for night or day operation.

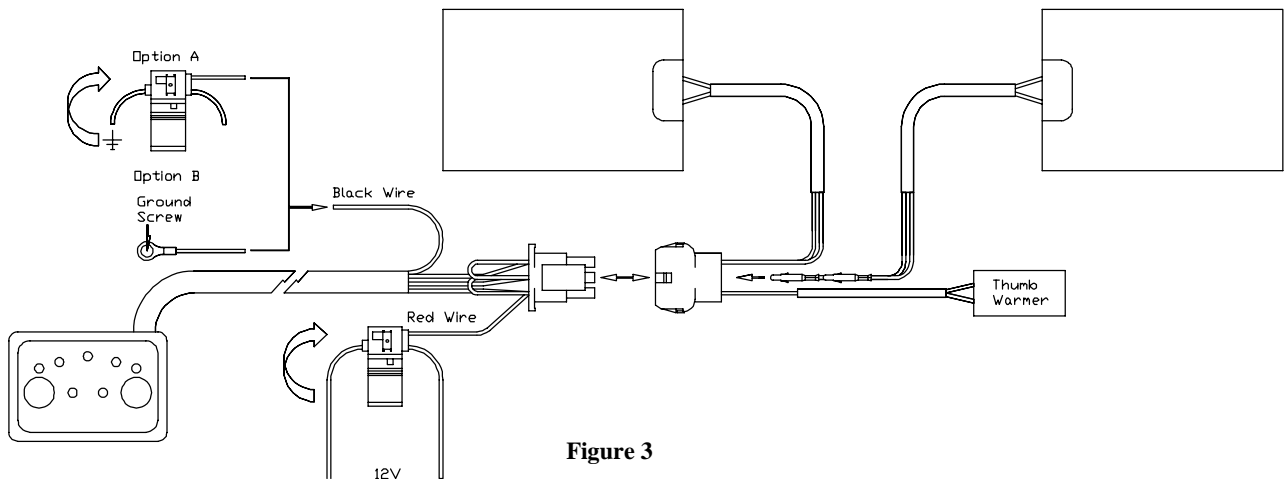

Figure 3